

Dear users:

Thank you for choosing KEXIN induction heating equipment, induction heating equipment KEXIN end selection of imported components, using the most advanced technology coupled with excellent craft production made. Continuous innovation in recent years was finally complete a number of high-end models, with high efficiency and good working conditions, heating quickly, easy to operate and so on. Compared with other similar products energy-saving 10% -40%, and compared with the old IF-saving more than 50% so that in the same industry that have a high level.

In the installation of this device, please read this manual, and operational staff rigorous training in order to make better use of the product.

In case there are any questions, please contact our factory technicians or after-sales service hot line so that we can better serve you.



## Installation issues

Table 1:

Model	Power	Power cables
KX-5188A120	120KW	≥35mm <sup>2</sup>

Distribution power capacity, cable diameter, and external air switching capacity

Single-core multi-strand copper cable, if use with aluminum cable, the diameter should be doubled.

## Section Letter induction heating equipment, detailed parameter table

Model	Standard power	Oscillation frequency	Oscillation current
KX-5188A120	120KW	10-40KHz	5-180A

## Power Requirements

1. Equipment must be reliable and grounded as required, or may cause electric shock or fire as accidents! The grounding wire by copper cable or aluminum cable should be connected according to electrical requirements or factory technical personnel required to connect.
2. External power supply must have sufficient margin and reliability. Equipment should have sufficient space for the installation and maintenance of space. Wiring must be installed with the strict requirements under the national standard by professionals.
3. Before the device is connected well or not double-checked, do not connect the power.

## Cooling water requirements:

1. This equipment should be installed with water-cooling circulation system, the user should build the pool according to the technical requirements, use water pumps, also suggest to install the cooling towers.
2. To ensure clean water, make sure that ponds don't have any debris or any water shut-off

---

material, if necessary, to install with filter.

3. Water temperature should be controlled between 5-35 ° C.

4. In order to avoid the foulings in equipment to block the cooling system, the best PH value of water is 7-8.5.

5. Regularly descaling the equipment, to ensure stable operation of equipment in order to avoid unnecessary losses.

### **Environmental requirements**

1. The working area of the equipment should be adequate space for heat dissipation and maintenance space, avoid sun exposure, rain, humidity, dust and other environments.

2. Make sure that the working environment does not exist flammable or explosive substances, even acid or other corrosive gases, don't let any conductive objects or liquids enter into the equipment.

3. Should be avoided to work in high dust, high temperature, or high humidity environment.

4. Ambient temperature should be controlled at between 2-35 °C, the relative humidity no more than 90%.

5. When the ambient temperature is below 0 °C, the internal waterway system in the equipment will be damaged by frost. So if there is no work, it's better to clean up the water inside the device and then use compressed air to blow completely the residual water in it.

## Operational procedures

### Panel functions and operating instructions

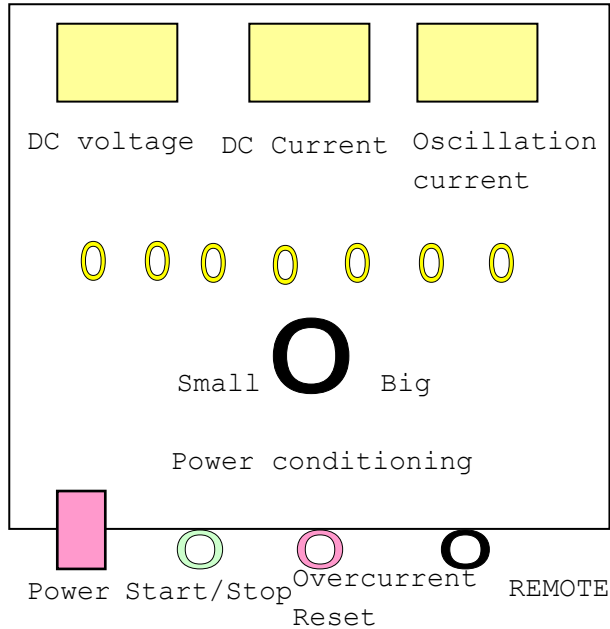

#### 1. DC Voltage Meter:

When the device is connected with power source, this display shows the DC voltage inside the device.

#### 2. DC ampere meter: it shows the output current value when works.

#### 3. Oscillation current meter:

In the heating mode, this digital display shows the oscillating current of the device, generally varied in 5-450; it depends on the chosen model and working power. The value shown by this digital display is proportional to the actual oscillation current, these data are not used as computing or engineering quantization, but only used as a qualitative observation of the device running way.

#### 4. Power Adjustment knob:

When heated, adjust the power knob to meet different heating temperature and speed requirements.

### 5. Heating / stop button:

In standby mode, press this button and then equipment start to heating operation. Press the button again, equipment will stop to heat.

### 6. Overcurrent reset button:

In working mode, due to a variety of causes which lead to over-current indicator light and with a continuous buzzing sound, the equipment will automatically stop working, it indicates that the equipment is under over-current protection. At this condition, just to press this overcurrent reset button, equipment will turn to work as normal.

### 7. Remote control socket:

It is used to connect with the remote control switch or foot switch, so that to achieve remote control operation.

## Use of equipment steps

1. Firstly of all, check if the equipment is well connected, if the cooling water is well connected, if the working environmental meets the requirements, if the power voltage is normal.

2. Connect with the appropriate induction coil and check if it exists short circuit, open circuit, leakage, water shutoff and so on. Sensors should not be connected with any other metal substances, such as machine tools, stents, feeding mouth discharge port, etc.

### 3. Steps

- 1. Before start to work, make sure that the power switch on the operation panel is in "off" position and the work-stop button in "stop" position, adjust the power control knob into the minimum.
- 2. Connect the pump with power and check if water circulation is normal and ensure the adequate equipment flow and pressure of cooling water adequate.
- 3. After the equipment is connected with external power, then will hear the sound of ventilation operating. Then observe the DC voltage on the voltage meter close to 500V, press down the panel power switch, the power indicator light (red), and about 10 seconds later, the AC contactor pull-in.

- 4. Press the start/stop button, and the working indicator light (green), put the heating part into the induction coil and adjust the power knob to the right position, when the workpiece temperature meets the requirements, then turn down the power knob, pick up the heated workpiece, and then place in a new workpiece, repeat the above procedure.
- 5. At the end of the work, firstly turn down the power knob, then press the stop working button, and press down the panel power switch, then cut off the external power supply and pump power after 10 minutes.

## **Fault phenomena and elimination methods**

1. No Power Supply Instructions: Air switch, power switch does not be pressed; an external power failure; control circuit fuse is broken; air switch or power switch is damaged.
2. Start to work but can't heat: Check whether there is over-current, adjust down the power knob, then restart. After repeatedly restart, still no heating current, please contact our factory after-sales service..
3. Heating and suddenly stops: Induction coil and workpieces are short circuit; alarming or others. Remedy according to the following described alarming methods;
4. Fault indicator lights
  - 1. Overvoltage: Over-voltage indicator is on indicates voltage is higher than the 420V, the machine will automatically stop working.
  - 2. Water scarcity: water indicator light is on, it indicates that water flow is too small, water pressure is too low, pipes are not smooth so device automatically stops work.
  - 3. Over-temperature: when this light is on, it means that cooling water temperature is too high or transformer temperature is too high. At this point should immediately stop heating, keep water circulating after cooling, and then start to heat with smaller current.
  - 4. Over-current: over-current indicator is on, temperature is too high; the workpiece touch with the induction coil; induction coil turn to short circuit; equipment failure, etc. First stop working, and press the over-current reset button, adjust down the power and then start to work. If repeated many times still cannot work, please contact our factory after-sales for maintenance.

