

Yueqing Branch Electronic Instrument Co., Ltd.

High frequency induction heating equipment, technical parameters



45KW

Remark: This machine should be equipped with 550W self-priming pump

Volume(mm ³)	Main Engine 660 mmx290mmx410mm Auxiliary Engine 740 mmx340mmx380mm
Net Weight	65KG
Gross weight	85KG

First, the technical characteristics of

High frequency induction heating equipment is the use of the principle of electromagnetic induction, so that in the alternating magnetic field within the metallic materials induced current, thereby heating the material until molten heating equipment.

Are the exchange of high-frequency power circuit → DC → AC inverter circuits, the rectifier circuit into a DC can, and then using the inverter circuit to

convert the frequency of exchange of energy required to supply the heating load, power requirements of induction heating, requirements of the current large, high frequency in order to improve efficiency.

Section Letter licensing the use of high frequency heating equipment of international advanced all-solid-state semiconductor power devices, import of new high-power transistor chip and FET, high-speed switch control, the German Siemens IGBT component of imports, with perfect control, protection, display alarm circuit so that the whole process of induction heating the entire process of automatic tracking of frequency, power adjustable for the protection of safe, reliable, and display data clearly and accurately, and according to the size and heating power of sub-band profile, the design specifications for a variety of different types of models. With fast heating, heating Canton, small size, easy installation, simple operation ideal thermal equipment, less power consumption and effective to protect the full, safe and reliable performance and characteristics of the old-fashioned high-frequency equipment replacement and other additional products, a wide range used in brazing, heat treatment, through thermal forming, precious metal smelting, parts of the local tempering, hardening, heating up the area of other shape.

Second, technical parameters

Model	Input voltage (v)		Oscillation power (KAV)	Oscillation frequency (KHZ)	Output supply current (A)	Cooling water pressure (Mpa)	Weight (Kg)
KX-5188A45	Three-phase 380V	±10%	45	40-60	1700	0.15-0.2	70

Third, the capacity of power distribution, cable diameter and the external air switching capacity

Model	Power	Power cables	External open space
KX-5188A45	45KW	$\geq 16\text{mm}^2$	100A

Note: The cable for the single-core multi-strand copper wire, such as aluminum, to increase the diameter doubled

1. Equipment must be reliable and grounded as required, or may cause electric shock or fire as accidents! The grounding wire by copper cable or aluminum cable should be connected according to electrical requirements or factory technical personnel required to connect.

2. External power supply must have sufficient margin and reliability. Equipment should have sufficient space for the installation and maintenance of space. Wiring must be installed with the strict requirements under the national standard by professionals.

3. Before the device is connected well or not double-checked, do not connect the power.

Four, commonly used in cooling water system

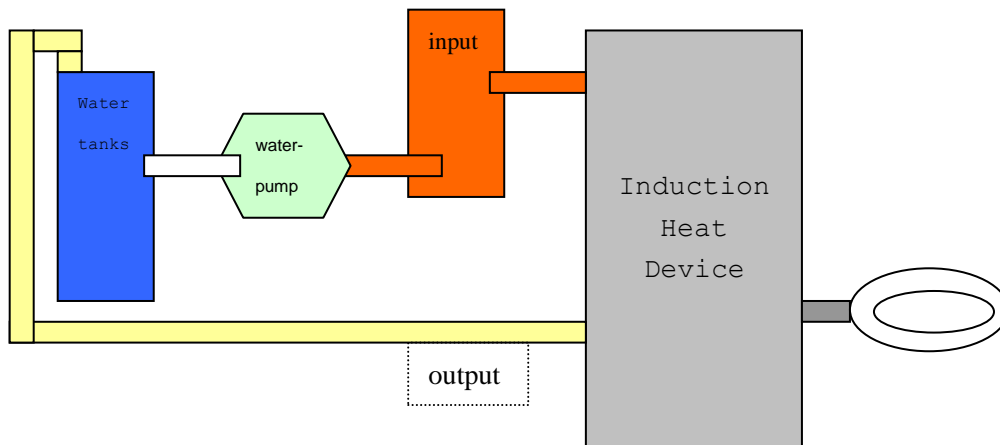

Five, cooling water requirements:

1. This equipment should be installed with water-cooling circulation system, the user should build the pool according to the technical requirements, use water pumps, also suggest to install the cooling towers.
2. To ensure clean water, make sure that ponds don't have any debris or any water shut-off material, if necessary, to install with filter.
3. Water temperature should be controlled between 5-35 ° C.
4. In order to avoid the foulings in equipment to block the cooling system, the best PH value of water is 7-8.5.
5. Regularly descaling the equipment, to ensure stable operation of equipment in order to avoid unnecessary losses.

Six, Environmental requirements

1. The working area of the equipment should be adequate space for heat dissipation and maintenance space, avoid sun exposure, rain, humidity, dust and other environments.
2. Make sure that the working environment does not exist flammable or explosive substances, even acid or other corrosive gases, don't let any

conductive objects or liquids enter into the equipment.

3. Should be avoided to work in high dust, high temperature, or high humidity environment.

4. Ambient temperature should be controlled at between 2-35 °C, the relative humidity no more than 90%.

5. When the ambient temperature is below 0 °C, the internal waterway system in the equipment will be damaged by frost. So if there is no work, it's better to clean up the water inside the device and then use compressed air to blow completely the residual water in it.

Seven, operating rules and regulations

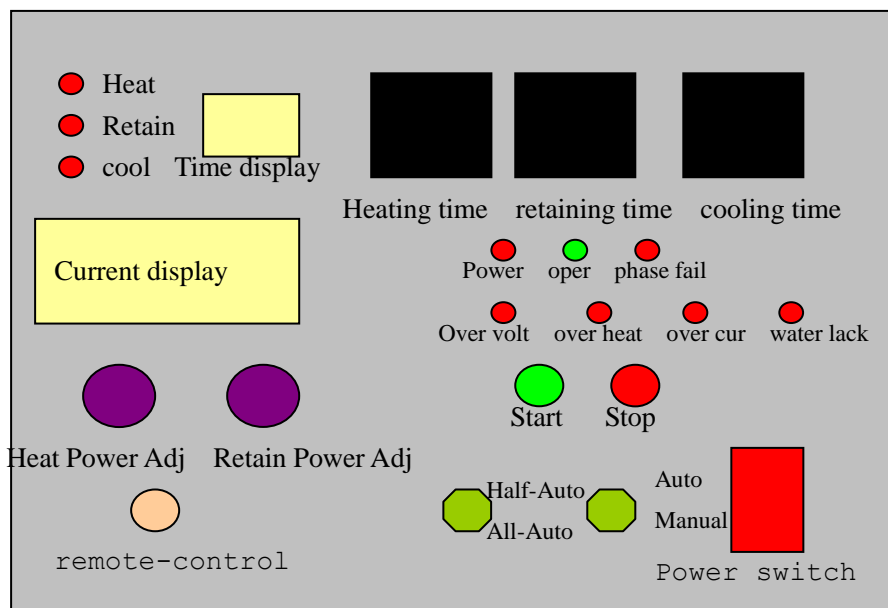

1, Heat power adjustment knob:

When heating, adjusting the knob can adjust the power, so that to meet the heating temperature and different needs of speed.

2, start / stop button:

In the standby mode, press down this button, the machine will operate with heating. And then press down the button again, equipment will stop heating.

3, Remote-control socket:

It's used as connection with remote-controlled switches or foot switches, in order to achieve far-controlled operation.

4, Adjusting the heating time, holding time and cooling time, set the machine into Automatic mode, then press the start button, the machine will automatically and circularly work in a state.

5, The power indicator light on the Control Panel display, when lights flashing it means work in normal.

6, When using the Remote Control, please note that the control pedal should be far away from the sensor wires. Or because of the magnetic field, the sensor will have the heating effect.

Eight, equipment using steps

1. Firstly of all, check if the equipment is well connected, if the cooling water is well connected, if the working environmental meets the requirements, if the power voltage is normal.

2. Connect with the appropriate induction coil and check if it exists short circuit, open circuit, leakage, water shutoff and so on. Sensors should not be connected with any other metal substances, such as machine tools, stents, feeding mouth discharge port, etc.

3. Steps

- 1. Before start to work, make sure that the power switch on the operation panel is in "off" position and the work-stop button in "stop" position, adjust the power control knob into the minimum.

- 2. Connect the pump with power and check if water circulation is normal and ensure the adequate equipment flow and pressure of cooling water adequate.

- 3. After the equipment is connected with external power, then will hear the sound of ventilation operating. Then observe the DC voltage on the voltage meter close to 500V, press down the panel power switch, the power indicator light (red), and about 10 seconds later, the AC contactor pull-in.

- 4. Press the start/stop button, and the working indicator light (green), put the heating part into the induction coil and adjust the power knob to the right position, when the workpiece temperature meets the requirements, then turn down the power knob, pick up the heated workpiece, and then place in a new workpiece, repeat the above procedure.

- 5. At the end of the work, firstly turn down the power knob, then press the stop working button, and press down the panel power switch, then cut off the external power supply and pump power after 10 minutes.

Nine, fault phenomenon and troubleshooting

1. No Power Supply Instructions:

Air switch, power switch does not be pressed; an external power failure; control circuit fuse is broken; air switch or power switch is damaged.

2. Start to work but can't heat:

Check whether there is over-current, adjust down the power knob, then restart. After repeatedly restart, still no heating current, please contact our factory after-sales service..

3. Heating and suddenly stops:

Induction coil and workpieces are short circuit; alarming or others. Remedy according to the following described alarming methods;

4. Fault indicator lights

- 1. Overvoltage: Over-voltage indicator is on indicates voltage is higher than the 420V, the machine will automatically stop working.
 - 2. Water scarcity: water indicator light is on, it indicates that water flow is too small, water pressure is too low, pipes are not smooth so device automatically stops work.
 - 3. Over-temperature: when this light is on, it means that cooling water temperature is too high or transformer temperature is too high. At this point should immediately stop heating, keep water circulating after cooling, and then start to heat with smaller current.
 - 4. Over-current: over-current indicator is on, temperature is too high; the workpiece touch with the induction coil; induction coil turn to short circuit; equipment failure, etc. First stop working, and press the over-current reset button, adjust down the power and then start to work. If repeated many times still cannot work, please contact our factory after-sales for maintenance.

Ten, 45KW water heating equipment connection, as shown

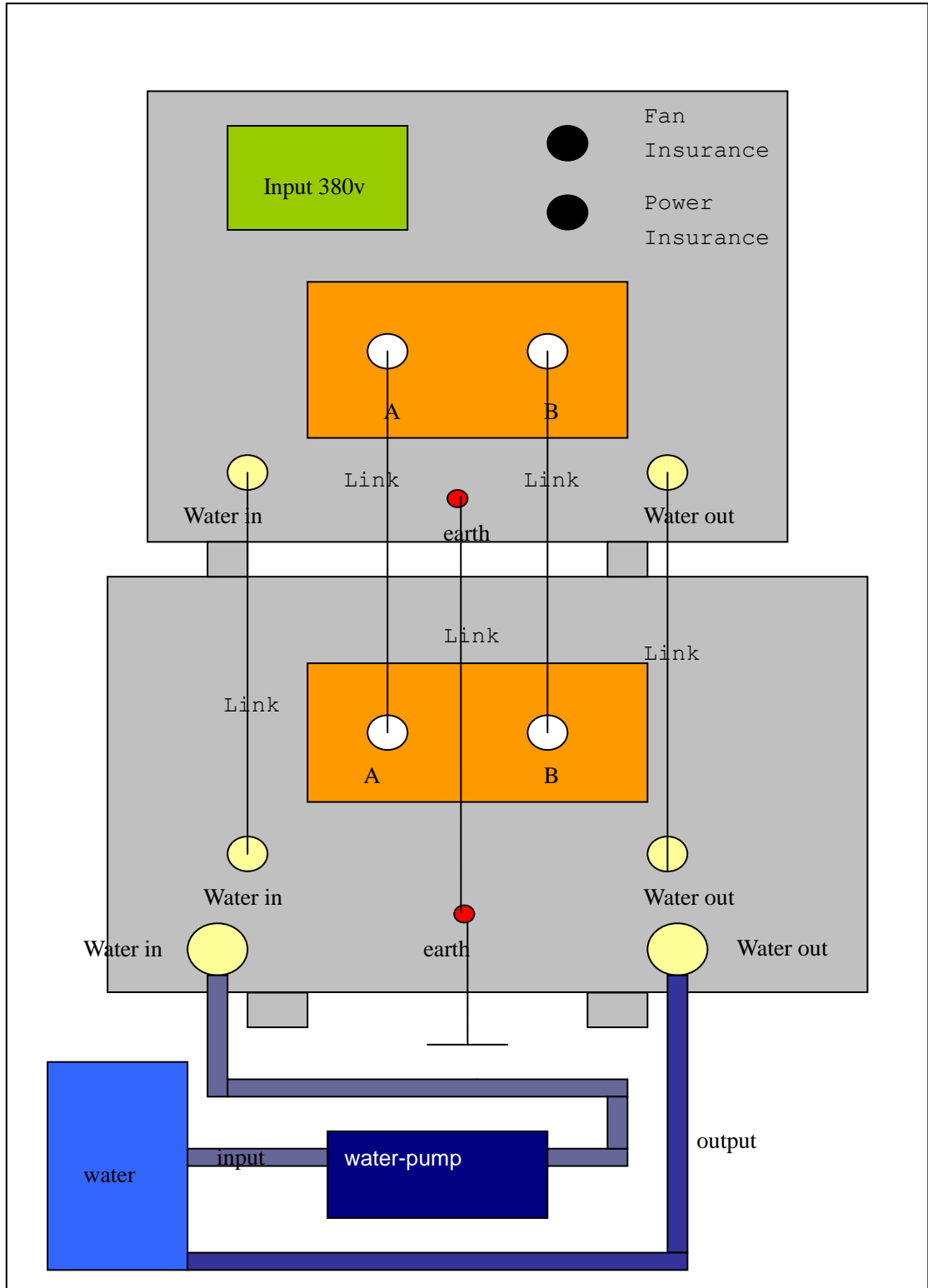

Product Application

1, through thermal forming

A, Hot upsetting, hot-rolled for various types of standard fasteners and other

mechanical parts, hardware tools, straight shank twist. 16mm in diameter of round steel, heat about 3-5 seconds, it can be in extrusion.

B, heat annealing of metallic materials in order to stretch, such as shape embossed. Such as tensile steel pipe, pipe, smashing heads, wire, nail-making heating wire, stainless steel products, annealing, elongation, raised type.

2, heat treatment

All kinds of hardware tools, electric, hydraulic, pneumatic components, gas distribution Motorcycle parts such as mechanical metal surface, within the hole, in part or in whole quenching, annealing, tempering, etc.. Such as hammers, knives, scissors, pliers and all kinds of shafts, cam, sprocket, gear, valve, ball-and large-scale machine tool sales, such as ductile iron rail and the quenching, the domestic production of many of the guide sprocket and machine tool manufacturers have the use of heat treatment equipment of the Company.

3, brazing

Segment types of cemented carbide, tools, milling, planning, reamer, diamond saw blades, serrated welding. Grinding, drilling, welding and cutting tools. Other hybrid welding of metallic materials. Such as brass, copper parts, valves, stainless steel bottom of the pot and so on.

4, metal smelting

Such as melting gold, silver, copper and so on.

5, heating the area of other Aluminum tube. Cable, wire, heating film. Food, beverage, pharmaceutical industry, the use of the aluminum foil seal, metal, such as the pre-expansion.

Note:

- 1. It should be equipped with 0.5~0.75KW self-sucking pump.**
- 2. Reservoir with capacity of 2~3 tons water.**
- 3. The water inside the machine should be replaced half a month a time.**
- 4. In winter, if the machine stops to work, remember to exhaust out the water inside the machine so that to avoid the water is frozen.**

Contact information:

Yueqing Kexin Electronic Instrument Co., LTD

Add: Sanli Industrial Zone, Liushi Town, Yueqing, Wenzhou, Zhejiang Province, China.

Tel: 0577-27872900; Fax: 0577-27872911

E-mail: nancy-sales@foxmail.com

Skype: nancyliu677

Whatsapp: +8615258628297

<http://www.hfinductionheater.com/>